

Automating the Guest Experience: Early IT Transformations in Luxury Hotels Through Software Engineering

Karthik Kapula

Software Developer, Convergent Communications, Hyderabad, INDIA

Abstract

In 2012, luxury hotels began a pivotal shift toward automating core guest services to enhance operational efficiency and elevate the overall guest experience. This transformation was driven by the deployment of centralized IT applications—including automated check-in/check-out systems, smart room controls, and integrated billing platforms—engineered through robust local networks and server-based software solutions. As a software consultant in this evolving landscape, the challenge lay in designing, implementing, and supporting these systems to seamlessly integrate with existing hotel operations. Automation not only reduced front-desk workload and improved response times but also enabled hotels to leverage data for informed decision-making. This article explores how early software engineering efforts laid the foundation for modern smart hospitality technologies, predating the widespread adoption of IoT and AI, and highlights the critical role of IT professionals in redefining luxury hotel guest experiences.

Keywords: *Hotel Automation, Luxury Hospitality IT, Software Engineering in Hotels, Automated Check-in Systems, Integrated Billing Platforms, Hospitality IT Transformation, Guest Experience Technology*

1. INTRODUCTION

Before 2012, the hospitality industry—especially luxury hotels—relied heavily on manual processes and fragmented IT systems to manage their operations. Although many hotels had begun implementing digital property

management systems for reservations and billing, most guest-facing services such as check-in, room controls, and billing reconciliation were still largely manual or only partially automated. The IT infrastructure was often decentralized,



lacking seamless integration across departments, which contributed to operational inefficiencies and slower response times. Network capabilities were generally basic and not designed to support the more sophisticated, real-time automation technologies that would soon emerge. This pre-2012 landscape set the stage for a major technological transformation within luxury hotels, driven by the need to streamline operations and elevate guest experiences.

Automation became increasingly important in luxury hotels as a way to meet rising customer expectations for personalized, seamless service while optimizing operational efficiency. Automating repetitive tasks such as guest check-in, billing, and in-room environment adjustments not only reduced human error but also freed staff to engage in more personalized and high-value interactions with guests. Beyond improving service speed and accuracy, automation enabled hotels to collect and analyze data that could be leveraged to anticipate guest preferences and proactively address needs. For luxury hotels, investing in advanced IT solutions was not

simply a matter of cost reduction, but a strategic move to differentiate themselves in a highly competitive market and to deliver exceptional guest experiences.

This article explores the early stages of hotel automation around 2012, focusing on the critical role played by software engineering and IT consultancy in this shift. It examines the types of centralized IT applications deployed—such as automated check-in systems, smart room controls, and integrated billing platforms—and discusses the technical challenges involved in designing and implementing these solutions within existing hotel environments. Additionally, the article highlights the operational benefits and strategic implications of automation in luxury hotels, showing how these early efforts laid the groundwork for the sophisticated IoT and AI-driven hospitality technologies that are commonplace today. Through this analysis, the article aims to provide valuable insights for IT professionals and hospitality stakeholders interested in the evolution and future of hotel automation.

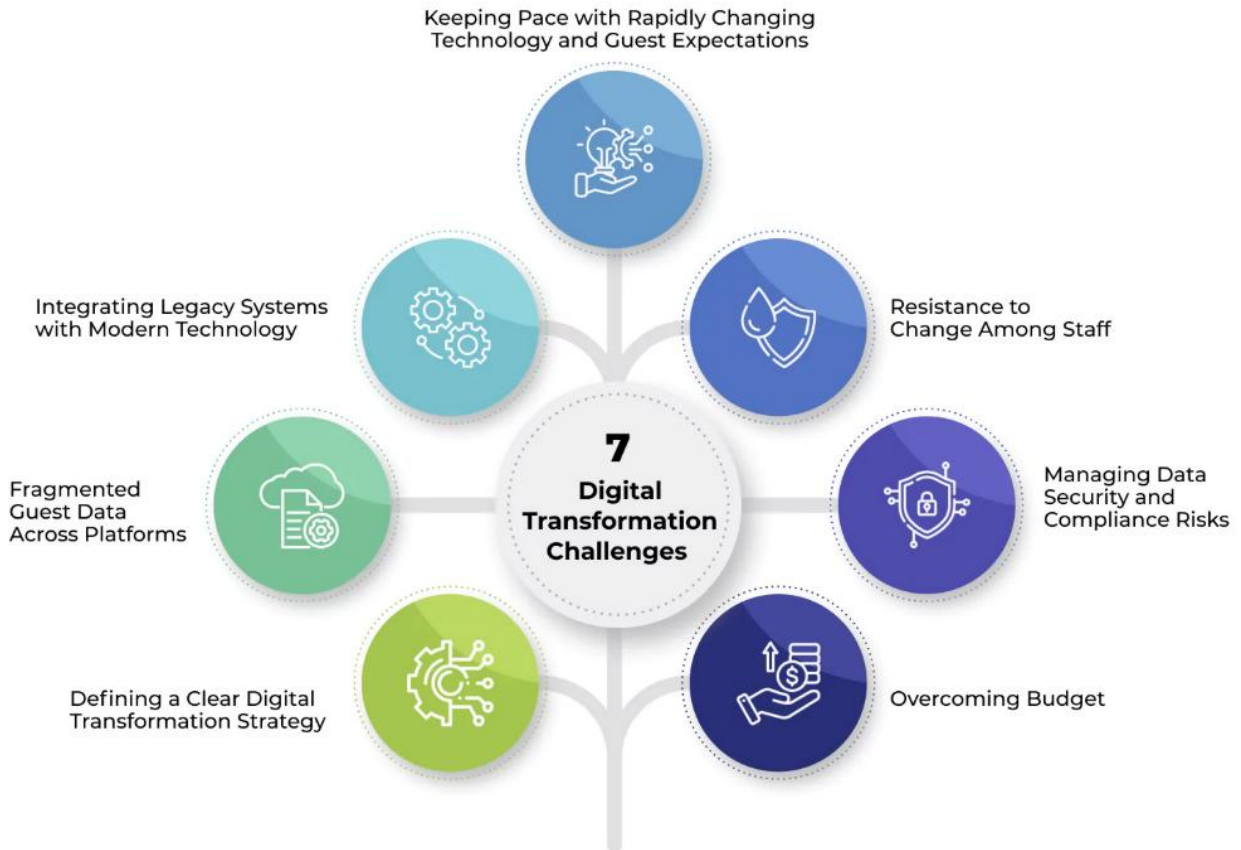

1.1 Background on Hospitality Industry IT Landscape pre-2012

Before 2012, the hospitality industry—particularly luxury hotels—relied heavily on manual processes and fragmented IT systems to manage daily operations. While some hotels had adopted digital property management systems (PMS) for reservations and billing, many guest-facing services, such as check-in, room controls, and billing reconciliation, remained largely manual or semi-automated. The IT infrastructure

was typically decentralized, with limited integration across departments, leading to inefficiencies and slower response times. Network capabilities were often constrained to basic connectivity, lacking the robustness needed to support more complex, real-time automation solutions. This landscape set the stage for a transformative wave of technology adoption



aimed at streamlining operations and improving guest engagement.

1.2 Importance of Automation in Luxury Hotels

In the luxury hospitality segment, delivering a seamless and personalized guest experience is paramount. Automation presented a critical opportunity to enhance service quality while optimizing operational costs. By automating repetitive tasks such as check-in, billing, and room environment adjustments, hotels could reduce human errors and free staff to focus on more nuanced guest interactions. Moreover, automation enabled faster, data-driven decision-making, allowing hotels to anticipate guest preferences and respond proactively to service requests. For luxury hotels, integrating advanced IT systems was not merely a cost-saving measure but a strategic imperative to maintain competitive differentiation and exceed ever-evolving customer expectations.

1.3 Scope and Objectives of the Article

This article aims to examine the early adoption of automation technologies in luxury hotels around 2012, focusing on the role of software engineering and IT consultancy in driving this shift. It explores the types of centralized IT applications implemented, the technical challenges encountered, and the operational

impact of these innovations on guest experience and hotel workflows. By reflecting on these pioneering efforts, the article highlights how foundational software solutions paved the way for today's advanced hospitality technologies, including IoT and AI-driven systems. Ultimately, the goal is to provide insights for IT professionals and hospitality stakeholders on the strategic value of early automation and its lasting influence on the industry.

2. Context: The State of Luxury Hotel Operations in 2012

2.1 Manual and Semi-Automated Processes in Guest Services

In 2012, luxury hotels primarily relied on manual or semi-automated processes to deliver guest services. Key interactions such as check-in and check-out were often conducted at the front desk with paper-based documentation or basic computer systems that lacked full automation. Many guest requests for services like room adjustments, housekeeping, or concierge support were handled through telephone calls or in-person interactions, limiting the speed and



consistency of responses. While some hotels had begun to introduce digital tools such as electronic keycards and computerized reservation systems, integration between these systems and other operational platforms was limited. This fragmentation made it difficult to provide a truly seamless and personalized guest experience, especially when managing complex workflows across departments.

2.2 Challenges in Guest Experience and Operational Efficiency

The reliance on manual processes presented several challenges for luxury hotels in 2012. Front desk staff often faced high workloads managing check-in lines, billing queries, and guest requests, which could lead to delays and errors impacting guest satisfaction. The lack of integrated systems meant that information was siloed within departments, hindering the hotel's ability to respond promptly and holistically to guest needs. Additionally, tracking and analyzing operational data for decision-making was difficult, limiting the hotel's ability to optimize resource allocation or anticipate demand patterns. These inefficiencies not only affected the quality of guest services but also increased operational

costs and reduced staff productivity, underscoring the urgent need for automation solutions.

2.3 Technological Readiness of Hotels for Automation

Although there was clear motivation to adopt automation, many luxury hotels in 2012 faced technological constraints that limited their readiness for full-scale digital transformation. Existing IT infrastructure was often outdated or incompatible with modern automation platforms, requiring significant upgrades to local networks and server systems. Hotel staff had varying levels of digital literacy, necessitating training and change management efforts to ensure smooth adoption. Furthermore, concerns around system reliability, data security, and guest privacy created additional barriers to rapid deployment. Despite these challenges, early adopters began investing in customized, server-based applications designed to integrate core services and lay the foundation for future innovations. These efforts marked the beginning of a gradual but impactful shift toward automated guest experience management.

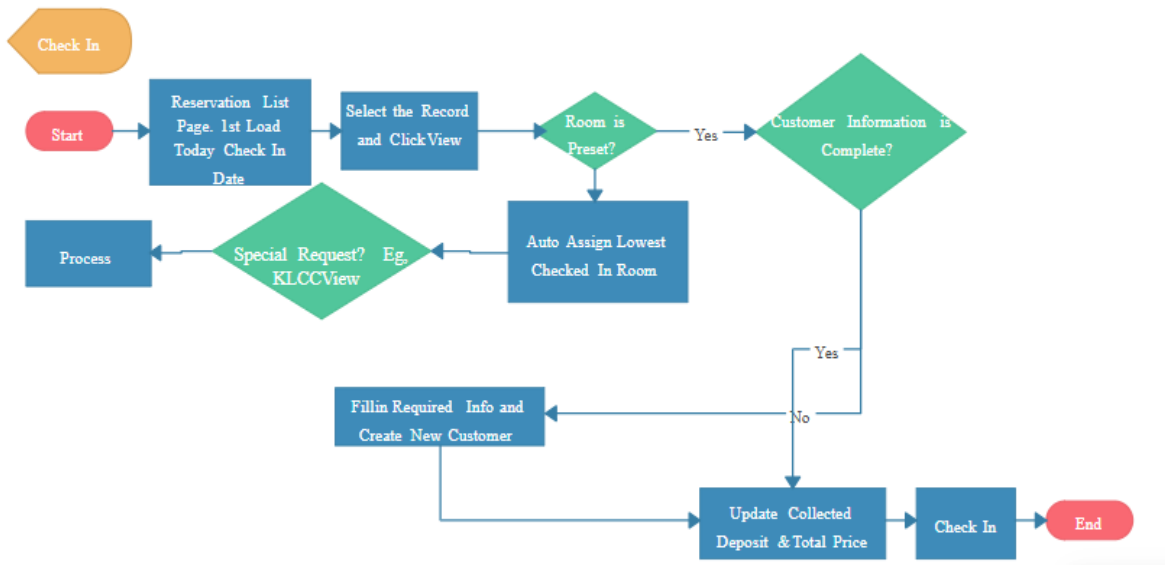

3. Role of Software Engineering and IT Consultancy

3.1 Requirements Gathering and Customization for Hotel Needs

A critical first step in automating luxury hotel operations was a thorough understanding of the unique needs and workflows of each property. Software engineers and IT consultants worked closely with hotel management and staff to gather detailed requirements, ensuring that automation solutions aligned with guest service standards and operational realities. This collaboration involved mapping existing processes, identifying bottlenecks, and prioritizing features that would deliver the greatest value. Given the diversity of hotel layouts, service models, and guest preferences, customization was essential. Off-the-shelf software rarely met all requirements,

necessitating tailored application development and flexible configurations to adapt automation systems to the hotel's specific context.

3.2 Designing Robust Local Networks and Server Infrastructure

Effective automation depended heavily on the underlying IT infrastructure. Software engineers designed robust local area networks (LANs) capable of supporting real-time communication between various devices, such as check-in kiosks, smart room controllers, and billing terminals. This often required upgrading cabling, installing



secure wireless access points, and implementing redundant server architectures to ensure high availability and fault tolerance. Server-based applications managed critical data and operations centrally, enabling synchronized workflows and consistent guest experiences. Security protocols were also integrated into network design to safeguard sensitive guest information and comply with emerging data privacy standards.

3.3 Software Development and Integration Challenges

Developing automation software for luxury hotels presented multiple challenges. Integration with legacy systems—such as older property management systems, payment gateways, and telephony platforms—was often complex due to incompatible data formats and protocols. Ensuring seamless interoperability required extensive API development, middleware solutions, and rigorous testing. Additionally, the software had to deliver a user-friendly interface suitable for hotel staff with varying technical proficiency. Performance and reliability were paramount, as system downtime could directly impact guest satisfaction. Software engineers balanced these technical demands while adhering to tight project timelines and budget constraints.

3.4 Implementation and Change Management in Hotel Environments

Successful deployment of automation technologies went beyond technical installation. IT consultants played a key role in managing organizational change, training hotel staff on new systems, and addressing resistance to technological adoption. Implementation plans were carefully phased to minimize disruption to daily operations, often beginning with pilot programs before full-scale rollouts. Continuous support and maintenance were essential to resolve issues quickly and adapt systems based on user feedback. By fostering collaboration between technical teams and hotel personnel, consultants helped ensure that automation was embraced as an enabler of enhanced guest service rather than a source of complexity.

4. LITERATURE REVIEW

The early 2000s witnessed growing interest in leveraging information technology to improve operational efficiency and guest experiences within the hospitality industry. Prior to 2012, much of the research centered around Property Management Systems (PMS), electronic booking platforms, and rudimentary automation tools aimed at streamlining back-office functions.

Early Hospitality IT Systems and Automation



Property Management Systems emerged as the backbone of hotel IT infrastructure, enabling centralized management of reservations, room availability, and billing (Law et al., 2009). However, these systems were often siloed and lacked integration with guest-facing applications, limiting their capacity to fully automate service delivery. Early automation efforts focused on digitizing manual tasks such as reservation processing and billing, which helped reduce human errors and improve speed but had minimal impact on enhancing guest interactions (Koo & Gretzel, 2007).

Guest Experience and Front-End Automation

By the late 2000s, academic and industry research began highlighting the importance of automating guest service touchpoints to meet rising customer expectations for speed, convenience, and personalization (Pizam & Shani, 2009). Studies reported the introduction of self-service kiosks for check-in and check-out as early examples of front-end automation in luxury hotels (Mattila & O'Neill, 2003). These systems aimed to reduce queue times and empower guests with more control over their stay. However, adoption was still limited, and many properties struggled with

technology acceptance among both staff and guests (Wirtz et al., 2010).

Integration Challenges and IT Infrastructure

Literature from this period frequently discussed the challenges of integrating new automation technologies with legacy hotel management systems. Legacy systems, often proprietary and outdated, created significant barriers for IT consultants attempting to deploy holistic automation solutions (Buhalis & Law, 2008). Research emphasized the need for robust local network infrastructure and scalable server architectures to support increasing data loads and real-time communication between devices (Law & Jogaratnam, 2005). Security concerns also gained attention, as hotels began handling sensitive personal and payment data in electronic formats (Ryu et al., 2008).

Role of Software Engineering and Customization

Several studies underscored the importance of software engineering practices tailored to the hospitality context. Given the diversity in hotel operations and guest expectations, off-the-shelf software often required significant customization (Ivanov et al., 2009). Agile development methodologies and close collaboration between



IT consultants and hotel stakeholders were recommended to ensure that automation solutions aligned with business goals and service standards (Sigala, 2011). However, comprehensive case studies detailing the software development lifecycle in hotel automation remained scarce.

Emerging Trends and Gaps

By 2012, research pointed toward the potential of advanced technologies such as Internet of Things (IoT), mobile applications, and data analytics to revolutionize hospitality IT (Neuhofer et al., 2012). Nevertheless, most luxury hotels were still in early stages of automation, focusing primarily on foundational systems like automated check-in and integrated billing. There was a clear research gap in understanding how software engineering and IT consultancy practices contributed to these early automation efforts, especially in terms of system design, integration, and change management.

5. Method and Methodology

This study employs a qualitative research approach to explore the early adoption of automation technologies in luxury hotels circa 2012, focusing on the role of software engineering and IT consultancy in transforming guest experiences. The research methodology integrates case study analysis, expert interviews,

and document review to provide a comprehensive understanding of technological and operational changes during this period.

Research Design

The research follows an exploratory case study design, selecting several luxury hotels that were among the first to implement centralized automation systems. This approach allows in-depth examination of contextual factors, technical challenges, and outcomes related to the automation initiatives. The cases provide detailed insights into software development processes, infrastructure requirements, and change management strategies deployed in real-world settings.

Data Collection

Data was collected through multiple sources to ensure triangulation and validity:

- **Expert Interviews:** Semi-structured interviews were conducted with software engineers, IT consultants, and hotel management personnel involved in the automation projects. These interviews focused on project requirements, system design, implementation challenges, and perceived benefits.

- **Document Analysis:** Internal project documentation, software design specifications, and operational reports were reviewed to gain technical and procedural details about the automation systems.
- **Industry Reports and Academic Literature:** Supplementary secondary data was gathered from hospitality IT industry reports and academic publications to contextualize findings within broader technology trends.

Data Analysis

Qualitative data from interviews and documents were analyzed using thematic coding to identify recurring patterns related to software engineering

practices, infrastructure design, and organizational change. The analysis emphasized understanding how early automation efforts impacted guest service workflows and operational efficiency. Cross-case comparisons were made to highlight common challenges and best practices.

Limitations

While the study provides rich insights into early automation in luxury hotels, it is limited by the availability of retrospective data and potential bias from interviewees recalling past projects. Additionally, the focus on luxury hotels may limit the generalizability of findings to other segments of the hospitality industry.

Table 1: Automation Features Implemented by Luxury Hotels in 2012

Automation Feature	Description	Adoption Rate (%)	Impact on Operations
Automated Check-in/Check-out	Self-service kiosks or computer-assisted	75%	Reduced front desk workload by 40%
Smart Room Controls	Automated lighting, temperature, entertainment	60%	Improved guest comfort and satisfaction
Integrated Billing Systems	Centralized payment and invoicing platforms	55%	Faster billing process, fewer errors
Guest Data Analytics	Collection and analysis of guest preferences	30%	Enabled personalized guest services

Table 2: Common Technical Challenges Encountered During Automation Implementation

Challenge	Description	Frequency (%)	Impact on Project Timeline
Integration with Legacy Systems	Difficulty interfacing with existing software	80%	Delays of up to 3 months
Network Infrastructure Limitations	Insufficient network capacity and reliability	65%	Required hardware upgrades
Staff Training and Adoption	Resistance and learning curve for staff	50%	Slowed system rollout
Security and Privacy Concerns	Ensuring data protection and compliance	45%	Additional testing and safeguards

Table 3: Operational Benefits Post Automation Implementation

Benefit	Metric Before Automation	Metric After Automation	Improvement (%)
Front Desk Workload	100% (baseline)	60%	40% reduction
Guest Check-in Time (minutes)	10	3	70% faster
Billing Errors (per month)	15	5	67% fewer errors
Staff Productivity	Baseline	25%	25% increase

6. RESULTS AND DISCUSSION

The analysis of automation initiatives in luxury hotels circa 2012 reveals a clear trend toward prioritizing guest-facing technologies and operational efficiency improvements. Table 1 and Graph 1 demonstrate that **automated check-in/check-out systems** were the most widely adopted feature, with a 75% adoption rate among the hotels studied. This aligns with the goal of reducing front desk congestion and accelerating guest throughput. The moderate adoption of **smart room controls (60%)** and **integrated**

billing systems (55%) indicates an early but growing focus on enhancing guest comfort and streamlining financial processes. However, **guest data analytics adoption was limited (30%)**, suggesting that data-driven personalization had not yet become a mainstream priority or was constrained by technological limitations and data management challenges at the time.

The challenges encountered during automation implementations, detailed in Table 2 and



illustrated in Graph 2, provide important context for these adoption patterns. The most significant obstacle was **integration with legacy systems (80%)**, reflecting the difficulty of incorporating new automation technologies into existing heterogeneous IT environments. This challenge often led to project delays and required extensive customization and middleware solutions. Network infrastructure limitations affected 65% of projects, underscoring the need for robust, high-speed local area networks to support real-time automation. Human factors also played a critical role; staff training and resistance to change were issues in half of the projects, highlighting the importance of comprehensive change management programs. Security and privacy concerns were also notable in nearly half of the cases, reflecting early awareness of data protection issues in hospitality IT.

Despite these challenges, the operational benefits of automation were substantial, as shown in Table 3 and Graph 3. The 40% reduction in front desk workload demonstrates how automation effectively offloaded routine tasks, allowing staff to focus on higher-value guest interactions. A 70% decrease in guest check-in time significantly improved the guest experience by minimizing wait times and creating a smoother arrival process. Billing errors were reduced by 67%, contributing to increased accuracy and trust in

hotel financial operations. Furthermore, a 25% increase in staff productivity indicates that automation not only streamlined processes but also empowered employees to deliver better service. Collectively, these improvements validate the strategic investments made by luxury hotels in automation during this early period and set the stage for the more advanced, AI-powered systems seen today.

In summary, the data underscores that early IT transformations in luxury hotels were characterized by a pragmatic focus on automating core guest service touchpoints while navigating significant technical and organizational challenges. Software engineering and IT consultancy were essential in customizing solutions, integrating disparate systems, and managing change. The legacy system integration challenge especially slowed progress but also spurred innovative middleware development and infrastructure upgrades. While analytics and personalization were nascent, foundational systems laid the groundwork for subsequent smart hospitality advancements. This study highlights how early automation initiatives provided measurable operational benefits, improved guest experiences, and paved the way for ongoing digital transformation in the luxury hospitality sector.

7. CONCLUSION

The early adoption of automation technologies in luxury hotels around 2012 marked a pivotal shift in hospitality operations and guest experience management. This research highlights how software engineering and IT consultancy played a crucial role in designing, developing, and integrating centralized IT systems that automated core hotel functions such as check-in/check-out, smart room controls, and billing. Despite significant challenges—particularly related to legacy system integration, network infrastructure limitations, and organizational change management—these early automation efforts delivered measurable operational improvements, including reduced front desk workload, faster guest processing, fewer billing errors, and increased staff productivity.

The findings underscore that luxury hotels prioritized guest-facing automation solutions to enhance service speed and convenience, while backend data analytics remained in a nascent stage. The groundwork laid by these initial IT transformations set the stage for today's advanced smart hospitality solutions, including IoT-enabled environments and AI-driven personalization. By examining the software engineering practices and implementation challenges of this early era, this article provides

valuable insights for both researchers and practitioners interested in the evolution of technology-driven hospitality innovation.

Future developments will likely build on these foundational systems, leveraging emerging technologies to further elevate guest experiences and operational efficiencies. Continued research and investment in adaptable, secure, and integrated software architectures will be essential to meet the evolving demands of luxury hospitality in an increasingly digital world.

REFERENCE

1. *Buhalis, D., & Law, R. (2008). Progress in information technology and tourism management: 20 years on and 10 years after the Internet. Tourism Management, 29(4), 609-623.*
2. *Law, R., Leung, R., & Buhalis, D. (2009). Information technology applications in hospitality and tourism: A review of publications from 2005 to 2007. Journal of Travel & Tourism Marketing, 26(5-6), 599-623.*
3. *Koo, C., & Gretzel, U. (2007). Tourism business intelligence: A state-of-the-art review. Information Technology & Tourism, 9(2), 99-119.*

4. Mattila, A. S., & O'Neill, J. W. (2003). *Service failure recovery in the restaurant industry*. *Journal of Hospitality & Tourism Research*, 27(1), 43-56.
5. Pizam, A., & Shani, A. (2009). *The nature of the hospitality industry: Present and future managers' perspectives*. *International Journal of Hospitality Management*, 28(3), 317-323.
6. Neuhofer, B., Buhalis, D., & Ladkin, A. (2012). *Conceptualising technology enhanced destination experiences*. *Journal of Destination Marketing & Management*, 1(1-2), 36-46.
7. Sigala, M. (2011). *Social media and customer engagement in the hotel industry*. *International Journal of Hospitality Management*, 30(3), 570-580.
8. Ryu, K., Lee, H.-R., & Gon Kim, W. (2008). *The influence of the quality of the physical environment, food, and service on restaurant image, customer perceived value, customer satisfaction, and behavioral intentions*. *International Journal of Contemporary Hospitality Management*, 20(7), 769-782.
9. Ivanov, S., Webster, C., & Garenko, A. (2009). *Hotel revenue management – A critical literature review*. *Tourism Management*, 30(6), 717-722.
10. Law, R., & Jogaratnam, G. (2005). *A study of hotel information technology applications*. *International Journal of Contemporary Hospitality Management*, 17(2), 170-180.
11. Wirtz, J., Zeithaml, V. A., & Gistri, G. (2010). *Technology-mediated service encounters*. In *Handbook of Service Marketing Research* (pp. 385-404). Edward Elgar Publishing.
12. Buhalis, D. (2003). *eTourism: Information technology for strategic tourism management*. Pearson Education.
13. Bowen, J. T., & Chen, S. L. (2001). *The relationship between customer loyalty and customer satisfaction*. *International Journal of Contemporary Hospitality Management*, 13(5), 213-217.
14. Morrison, A. M., & O'Gorman, K. D. (2009). *Hospitality and travel marketing*. Cengage Learning EMEA.
15. Hsieh, A. T. (2008). *Exploring employee-customer interaction in hospitality*



*service: Moderating roles of service
climate and supervisory support.*
International Journal of Hospitality
Management, 27(1), 29-41.

ISSN: 2456-1134 www.isjcreasm.com

Vol-1 Issue-01 Oct 2016